



OktaFlow[®] radial TK65

Multi-drop hot runner nozzle
radial version for side gating

TECHNICAL DATA

80HT

Melt channel Ød 7.5 mm

Operating voltage 230 V_{AC} *

Nominal length of the nozzle (L) in mm

65	95	135
■	■	■

ORT65

Quantity of tips 1, 2, 4 or 8

Operating voltage 230 V_{AC} *

Contact us for other nozzle lengths!

*Volts alternating current

■ available

NOTE

Power connector CMT and thermocouple connector CMLK are to be ordered separately.



PLUG LOCATION RELATIVE TO TIP

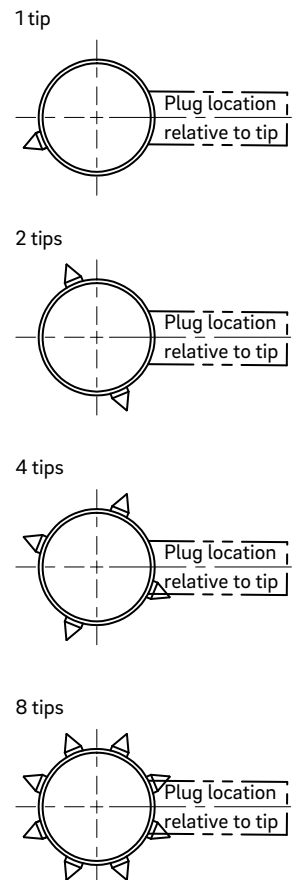

View B-B
Fastening screw thread and tip distance

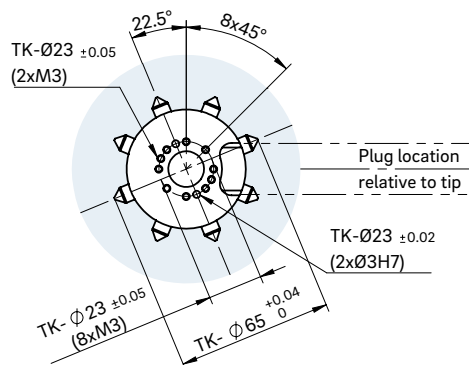



INSTALLATION

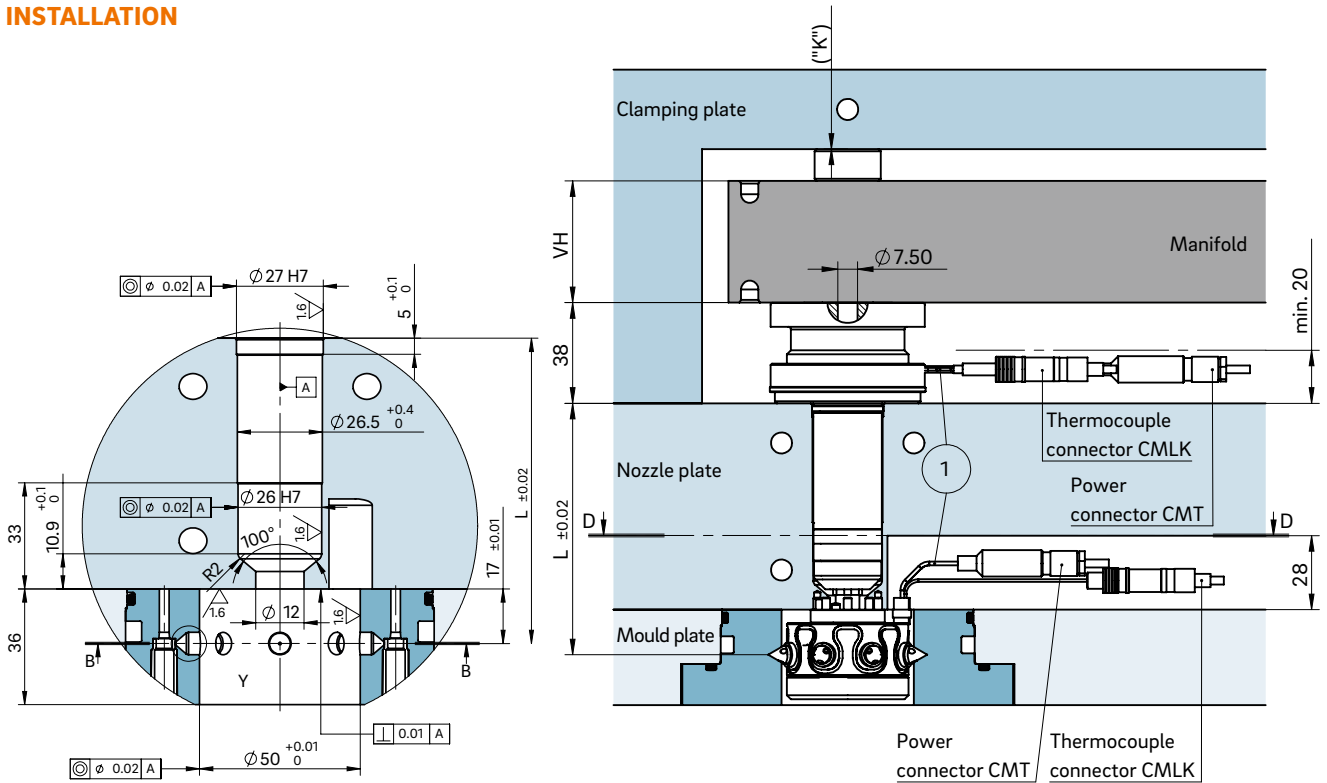

Gate point geometry

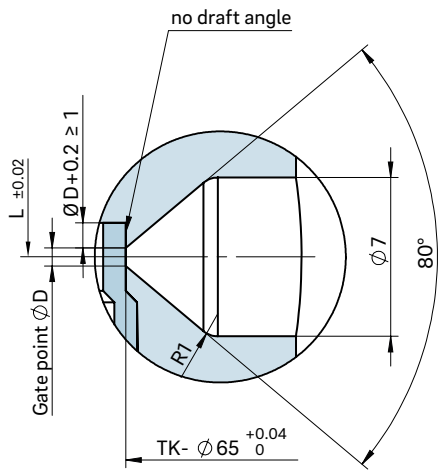

Example Cutout for nozzle head, power and thermocouple plug connections

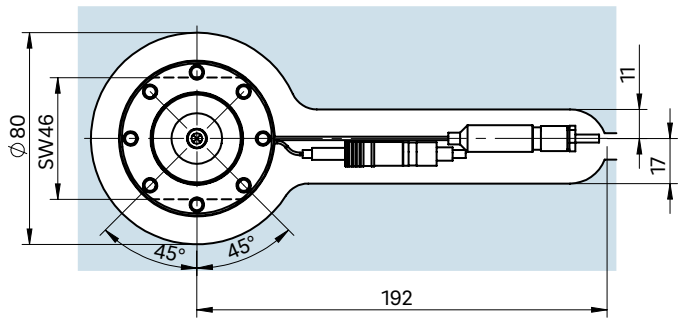

View D-D cutout for power and thermocouple plug connections of the sub-manifold

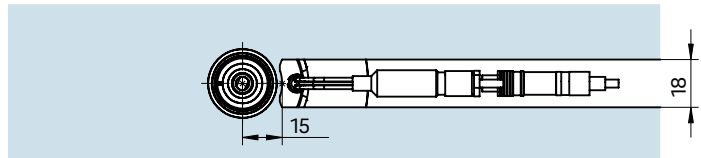

The size "K" required for heat expansion is to be ensured by grinding the pressure pads (12 + 0.1 mm)! Determine the difference between the height of the manifold system and the height of the frame plate when installed! ΔT specifies the temperature differential between the processing temperature and the mould temperature!

- ① Power and thermocouple plug connections in this area can only be bent once; minimum radius: R8
- SW = flat area on nozzle head

VH	ΔT (°C)	100	150	200	250	300	350
36 mm	K (mm)	0.021	0.059	0.098	0.137	0.177	0.217
46 mm	K (mm)	0.033	0.078	0.124	0.170	0.218	0.264
56 mm	K (mm)	0.046	0.097	0.150	0.203	0.258	0.311