



Hot runner nozzle type 8SET/8DET

Open single nozzle with conventional heating element

TECHNICAL DATA

8SET/8DET

Melt channel Ød 7.5 mm

Nozzle type SET – open with tip
DET – open with straight outlet

Operating voltage 230 V_{AC} *

Nominal length of the nozzle (L) in mm

50	60	80	100	120	150	200	250
■	■	■	■	■	□	□	□

Adapter straight (G)/radius (R)/
angle (W)

Contact us for other nozzle lengths!

*Volts alternating current

■ available □ on request

NOTE

Power connector CMT and thermocouple connector CMLK are to be ordered separately.



SET – open nozzle with tip
version "Tip"
Antechamber version A

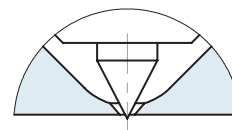

DET – open nozzle with straight outlet
version C
Antechamber version A

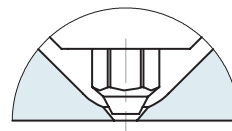

DET – open nozzle with straight outlet
version A
Antechamber version C

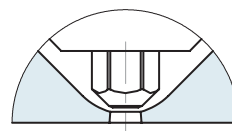

WEBCODE
21020



INSTALLATION

Open nozzle with tip
Nozzle type version C
Antechamber version A

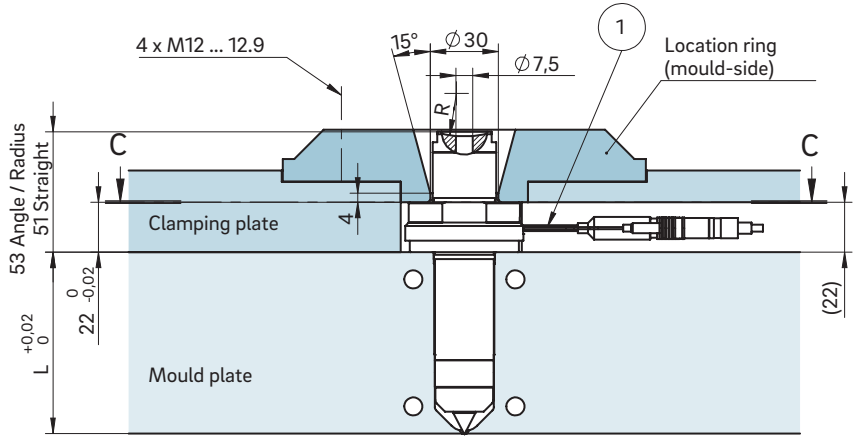
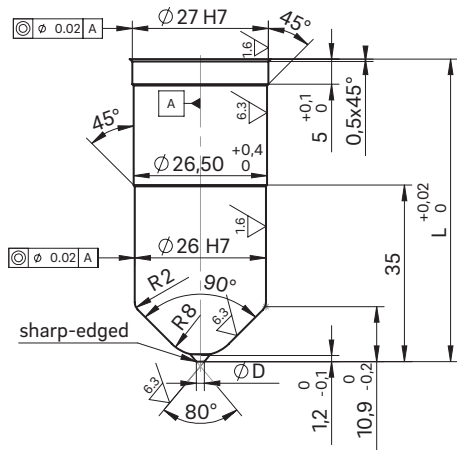

Cross-section C-C: Cutout for nozzle head, power and thermocouple plug connections

Open nozzle with straight outlet
Nozzle type version A
Antechamber version C

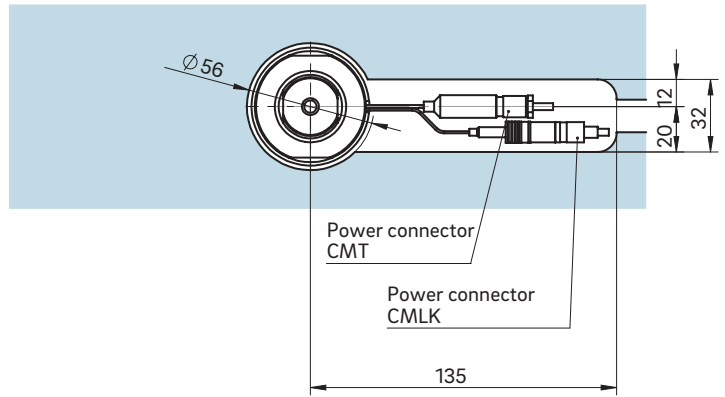
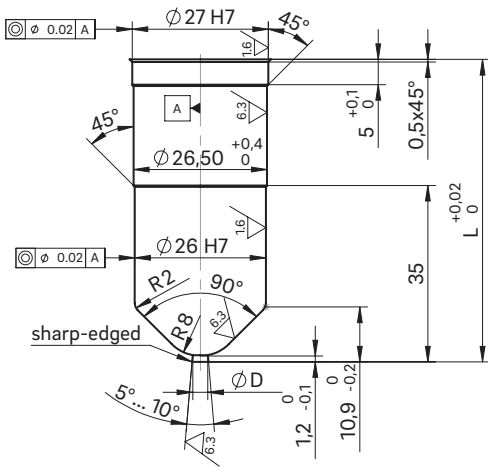

① Power and thermocouple plug connections in this area can be bent once; minimum radius: R8