



# Hot runner nozzle type 4SHF/4DHF

Open system nozzle with thick-film heating element (BlueFlow®),  
screwed to the manifold

## TECHNICAL DATA

### 4SHF/4DHF

Melt channel Ød	3.8 mm
Nozzle type	SHF – open with tip DHF – open with straight outlet
Operating voltage	230 V <sub>AC</sub> *

#### Nominal length of the nozzle (L) in mm

50	60	80	100	120	150	180
■	■	■	■	■	□	□

Contact us for other nozzle lengths!

\*Volts alternating current

■ available □ on request

## NOTE

Power connector CHF and thermocouple connector CMLK are to be ordered separately.

**BlueFlow® hot runner nozzle type SHF/DHF is not intended for sale or use in the USA or Canada!**



SHF – open nozzle with tip  
version "Tip"  
Antechamber version A

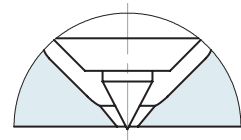

DHF – open nozzle with straight outlet  
version C  
Antechamber version A

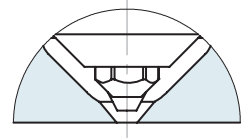

DHF – open nozzle with straight outlet  
version A  
Antechamber version C

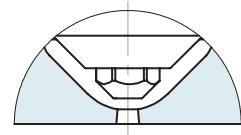



**INSTALLATION**

Open nozzle with tip  
Nozzle type version C  
Antechamber version A

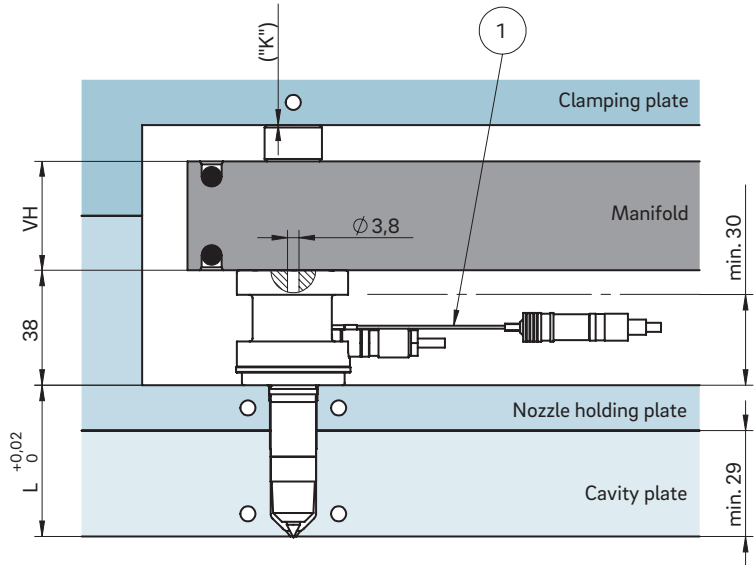
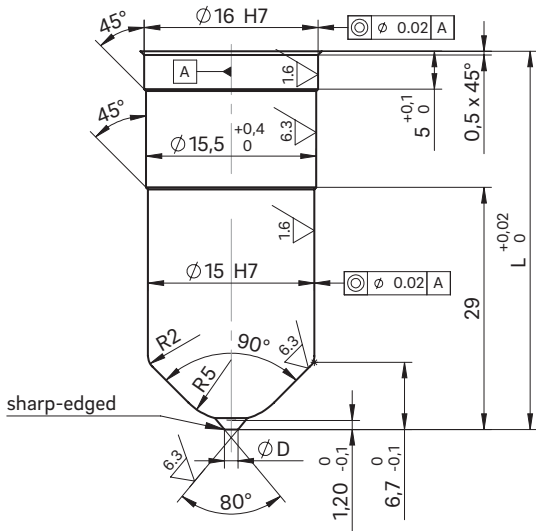

Example cutout for nozzle head, power and thermocouple plug connections

Open nozzle with straight outlet  
Nozzle type version A  
Antechamber version C

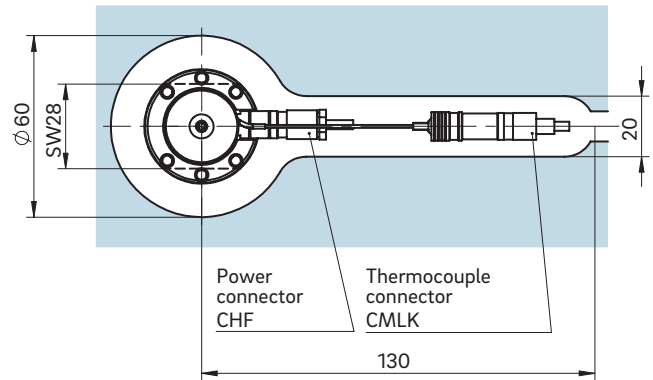
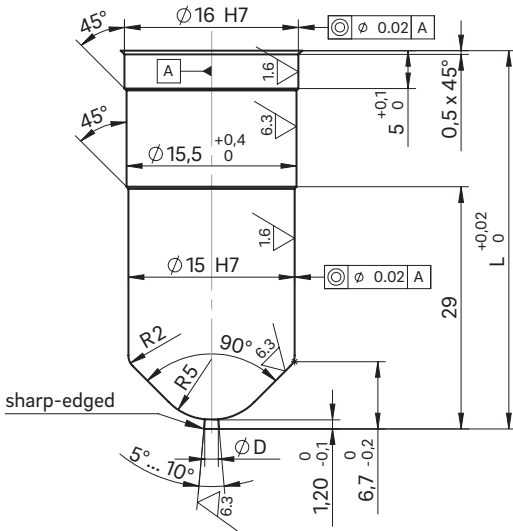

① Thermocouple plug connection in this area can only be bent once; minimum radius: R8  
SW = flat area on nozzle head

Dimension "K" required for heat expansion is to be ensured by grinding the pressure pad (12 + 0.1 mm)! Determine the difference between the height of the manifold system and the height of the clamping plate when installed! ΔT specifies the temperature differential between the processing temperature and the mould temperature!

VH	ΔT (°C)	100	150	200	250	300	350
36 mm	K (mm)	0.021	0.059	0.098	0.137	0.177	0.217
46 mm	K (mm)	0.033	0.078	0.124	0.170	0.218	0.264
56 mm	K (mm)	0.046	0.097	0.150	0.203	0.258	0.311