



Accessories



9 Accessories

	Page
Pressure pad	20
Spacer	20
Retaining clip	20
Spacer disks	30
Titanium ring for nozzle head	30
Pry bar	30
Insulating caps	40
Socket spanners for nozzle tips	40
OktaFlow® installation tools	40
Tools for removal	50
Needle adjustment	60
Spare parts	60
Metal O-ring	70
Lubrication	80
Cleaning	80



PRESSURE PAD

Pressure pad includes a cylinder screw
DIN EN ISO 4762 – M4 × 12 – 12.9

Note

The titanium pressure pad guarantees minimal heat transfer and is required for supporting the nozzle and manifold in relation to the clamping plate. The pressure pad is supplied in nominal size 12. The size "K" required for heat expansion of the manifold is to be ensured on the customer side by grinding the pressure pad.

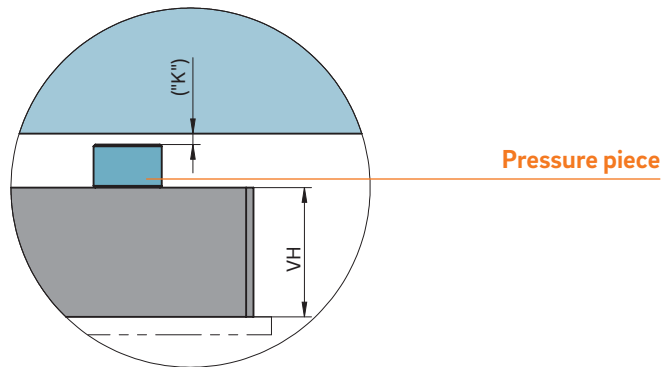

The size "K" required for heat expansion is to be ensured by grinding the pressure pad (12 + 0.1 mm)! Determine the difference between the height of the manifold system and the height of the frame plate when installed! ΔT specifies the temperature differential between the processing temperature and the mould temperature!

Order designation	ØA (mm)
817.233	19 ¹⁾
817.250	25 ²⁾

¹⁾Nozzles with a melt channel Ø 4–6 mm
²⁾Nozzles with a melt channel Ø ≥ 8 mm

VH	ΔT (°C)	100	150	200	250	300	350
36 mm	K (mm)	0.021	0.059	0.098	0.137	0.177	0.217
46 mm	K (mm)	0.033	0.078	0.124	0.170	0.218	0.264
56 mm	K (mm)	0.046	0.097	0.150	0.203	0.258	0.311

SPACER

Note

The spacer is required for supporting the manifold in relation to the location ring.

Order designation	
117.786	Includes one cylinder screw DIN EN ISO 4762 M5 × 40 – 12.9

For nozzle type _HF, _HT and _MT

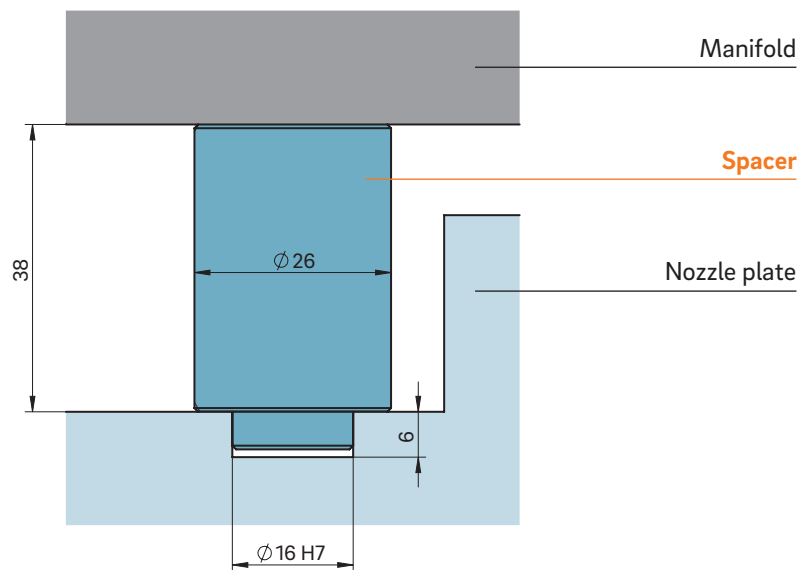

For nozzle type _TT

Order designation	
757.802	Includes one cylinder screw DIN EN ISO 4762 M5 × 16 – 12.9

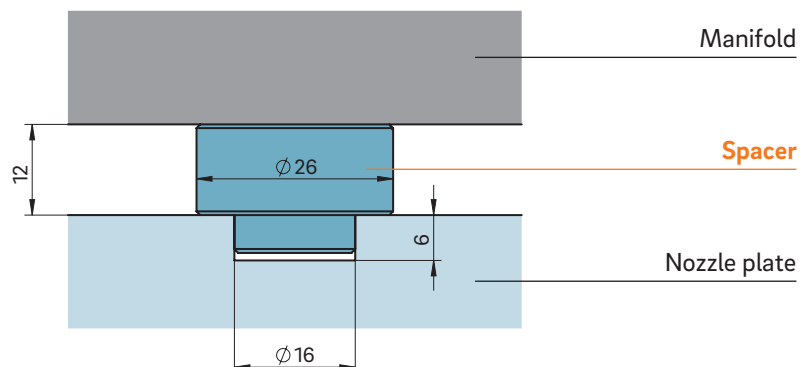



RETAINING CLIP FOR CABLES

Note

Using the retaining clip, the power and temperature sensor cables can be secured in the cable duct. The retaining clip is made of spring steel and is lodged in the cable duct under pretension.

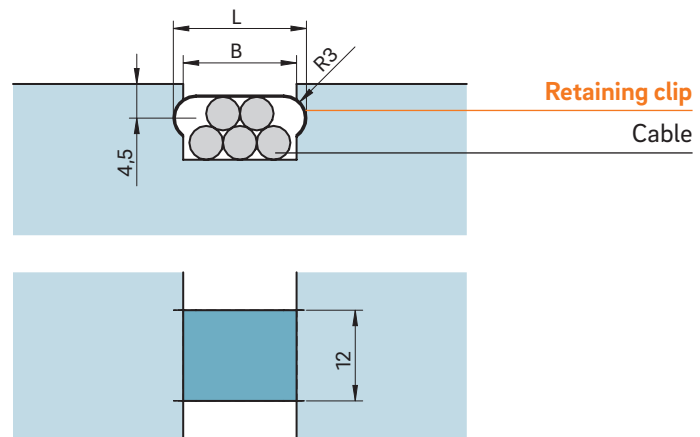

Order designation	Retaining clip L (mm)	Cable duct B (mm)
119.038	17.6	15
119.039	27.6	25
119.040	42.6	40



SPACER SHIMS

Note

The position of the nozzles can be adjusted using spacer shim at the gate point. If used in conjunction with a manifold, the pressure pieces/spacer bars must be adjusted to the shim thickness accordingly.

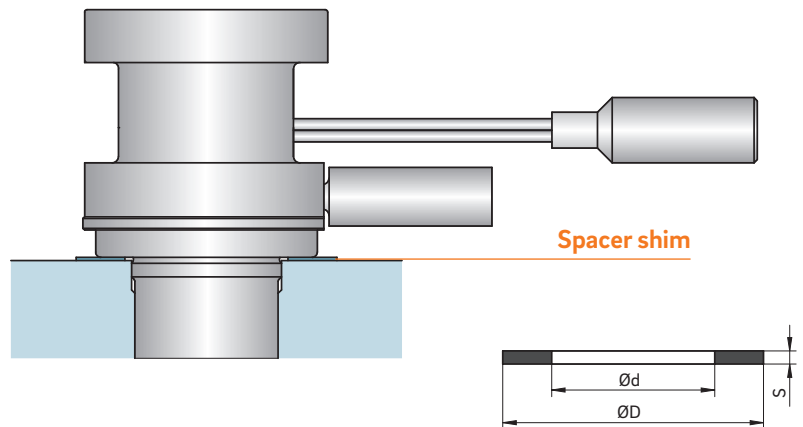

Order designation	s (mm)	Spacer shim dimensions		Nozzle type											
				SHF/DHF			SHT/DHT			SMT/DMT			SMT30K/DMT30K	SMF30K/DMF30K	
				4	5	6	5	6	8	4	5	6	5	5	
		Ød (mm)	ØD (mm)												
117.203	0,1	23,0	37,5			•	•					•	•		•
117.204	0,2	23,0	37,5			•	•					•	•		•
117.205	0,3	23,0	37,5			•	•					•	•		•
117.206	0,1	27,5	37,5						•					•	
117.207	0,2	27,5	37,5						•					•	
117.208	0,3	27,5	37,5						•					•	
818.1364	0,1	27,5	54,0							•					
818.1365	0,2	27,5	54,0							•					
818.1366	0,3	27,5	54,0							•					
818.1383	0,1	16,2	26,0	•											
818.1384	0,2	16,2	26,0	•											
818.1385	0,3	16,2	26,0	•											
818.1786	0,1	19,5	32,0		•										
818.1787	0,2	19,5	32,0		•										
818.1788	0,3	19,5	32,0		•										



TITANIUM RING FOR NOZZLE HEAD

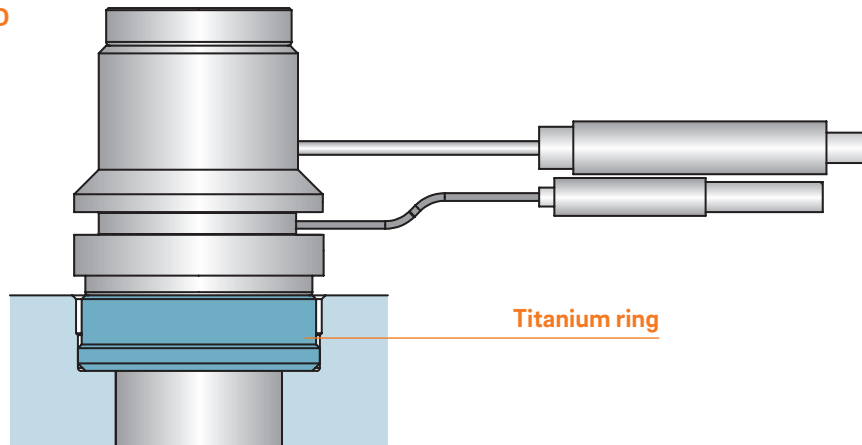

Order designation	SHF/DHF			SMT/DMT			SHT/DHT			SEF
	4	5	6	4	5	6	8	10	12	5
818.985				•						
818.986					•					
818.987						•				
818.1202			•							
818.1500	•									
818.1501		•								
818.1640							•			
818.1641								•		
818.1642									•	
818.1727										•

PRY BAR

Order designation	
865.000	Length: 400 mm □ = 14 mm

Note
The pry bar is used for the removal of hot runner nozzles from the gate bushing or mould plate.

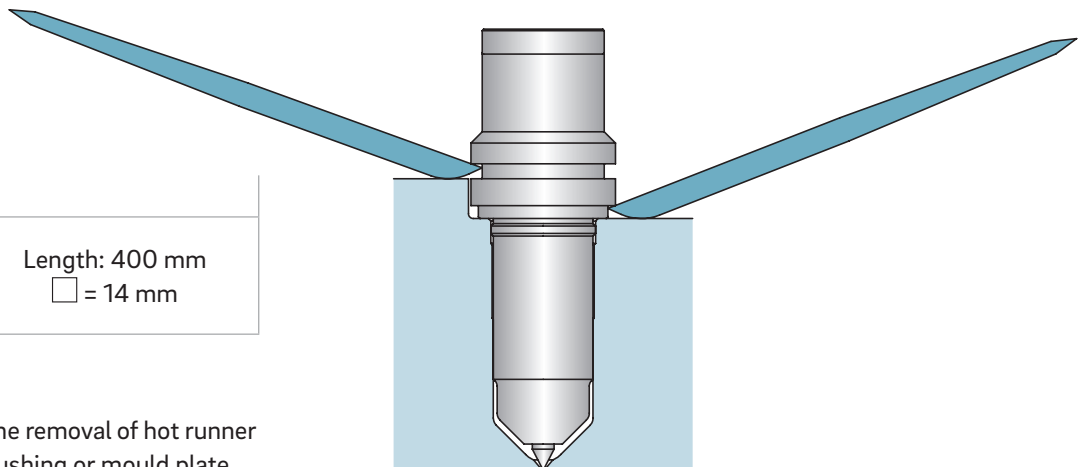



INSULATING CAPS

Note

Insulating caps are required for carbon fibre-filled and metal fibre/metal powder-filled plastics. We recommend the insulating caps for thermally sensitive plastics and for frequent colour changes as well.

The temperature resistance is approx. 350 °C.

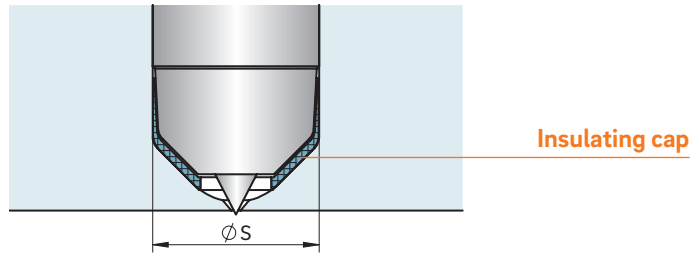

Order designation	ØS (mm)	Nozzle type							
		SEF/DEF	SET/DET	SHF/DHF			SHT/DHT		
		5	8	4	5	6	5	6	8
817.183	15			•					
817.184	22						•		
817.185	18	•			•				
817.186	26							•	
817.189	32		•						
817.190	22					•			
817.195	26								•

Order designation	ØS (mm)	Nozzle type								
		SMT/DMT			SMT30K/DMT30K	SMF30K/DMF30K	STT/DTT			
		4	5	6	5	5	8	4	5	6
817.182	20	•								
817.183	15							•		
817.184	22		•		•					
817.185	18					•			•	
817.186	26			•						
817.190	22									•
817.195	26						•			



SOCKET SPANNERS

Socket spanners for nozzle tips
for installing and removing nozzle tips

Order designation	Nozzle size (mm)
817.693	4
817.695	5
817.697	6
817.699	8



OKTAFLOW® INSTALLATION TOOLS

Extractor for OktaFlow® distribution
for the removal of OktaFlow® multi-drop hot runner nozzles

Order designation	Pitch circle Ø (mm)
818.1638	45
818.1639	65



Removal aid for OktaFlow® nozzle tips
for the removal of OktaFlow® multi-drop nozzle tips

Order designation	Pitch circle Ø (mm)
818.1637	45
818.1643	65





REMOVAL OF NEEDLE GUIDE WITH THREAD TYPE 4-8

Extractor set

for the removal of needle guides with a thread, includes extraction nut

Order designation	Nozzle size (mm)
757.766	4
757.767	5
757.768	6
757.805	8



Extraction nut

for the removal of needle guides with a thread

Order designation	Nozzle size (mm)
818.855	4
818.762	5
818.771	6
818.903	8
818.1309	10
818.1293	12



REMOVAL OF NEEDLE GUIDE WITH THREAD TYPE 8-12

Extractor

for the removal of needle guides with a thread

Order designation	Nozzle size (mm)
757.822	8, 10 and 12





REMOVAL

Extractor

for the removal of sealing plugs from the manifold

Order designation	
198	



Removal aid for assembly seal

for the removal of needle seals in the manifold

Order designation	Ø of assembly seal (mm)
818.736	2
818.737	3
818.738	5
818.1308	8



Removal aid for needles

for the removal of needles

Order designation	Needle Ø (mm)
818.733	2
818.734	3
818.735	5



SINGLE-NEEDLE VALVE

Removal aid for single-needle valve

for the removal of the single-needle valve (ENV)

Order designation	Needle Ø (mm)
818.730	2
818.730	3
818.731	5

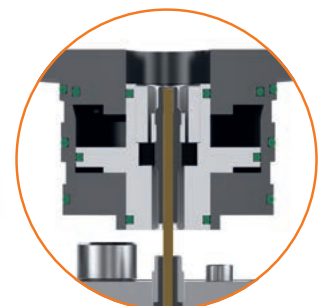



NEEDLE ADJUSTMENT AND ACCESSORIES

Socket spanner set – extended

for the setting/adjustment of needles

Order designation	Needle Ø (mm)
80.516	2
80.517	3
80.518	5

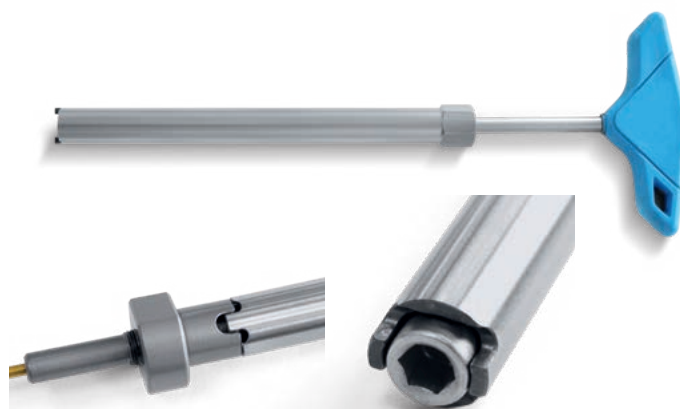

Socket spanner – extended

for the setting/adjustment of needles

Order designation	Needle Ø (mm)
80.757	2
80.758	3
80.759	5



Hex socket spanner with T-handle

for the setting/adjustment of needles

Order designation	Needle Ø (mm)
865.014	2
865.015	3
865.016	5





SPARE PARTS

Assembly seal

in manifold for valve gate systems

Order designation	Needle Ø (mm)
752.315	2
752.316	3
755.801	5
757.805	8



Seal set (ENV)

for single-needle valve

Order designation	ENV
80.491	ENV2/10/O/G, ENV3/10/O/G
80.492	ENV2/10/L/G, ENV3/10/L/G
80.493	ENV2/10/O, ENV3/10/O
80.494	ENV2/10/L, ENV3/10/L
80.495	ENV5/12/O/G
80.496	ENV5/12/L/G
80.497	ENV5/12/O
80.498	ENV5/12/L



O = hydraulic, L = pneumatic, G = with housing

Seal set (EEV)

for single-needle valve

Order designation	EEV
80.734	EEV2-3/10/O
80.735	EEV2-3/10/O/G
80.804	EEV2-3/10/L
80.805	EEV2-3/10/L/G

O = hydraulic, L = pneumatic, G = with housing





SPARE PARTS

Needle guide type LA

for valve gate nozzles

Order designation	Type	Gate point Ø (mm)	Order designation	Type	Gate point Ø (mm)
118.530	4-LA	1.0	118.546	6-LA	1.4
118.531	4-LA	1.2	118.764	8-LA	1.6
118.532	4-LA	1.4	118.560	8-LA	2.0
118.513	5-LA	0.8	118.561	8-LA	2.5
118.514	5-LA	1.0	118.477	10-LA	3.0
118.515	5-LA	1.2	118.478	10-LA	3.5
118.516	5-LA	1.4	118.479	10-LA	4.0
118.543	6-LA	0.8	118.503	12-LA	3.0
118.544	6-LA	1.0	118.504	12-LA	3.5
118.545	6-LA	1.2	118.505	12-LA	4.0



Titanium ring for needle guide type LA

for valve gate nozzles

Order designation	Nozzle size (mm)					
	4	5	6	8	10	12
818.486		•	•			
818.488	•					
818.492				•		
818.496					•	•



Needle guide type LAZ

for valve gate nozzles

Order designation	Type	Gate point Ø (mm)	Order designation	Type	Gate point Ø (mm)
118.537	4-LAZ	0.8	118.553	6-LAZ	0.8
118.538	4-LAZ	1.0	118.554	6-LAZ	1.0
118.539	4-LAZ	1.2	118.555	6-LAZ	1.2
118.540	4-LAZ	1.4	118.556	6-LAZ	1.4
118.521	5-LAZ	0.8	118.765	8-LAZ	1.6
118.522	5-LAZ	1.0	118.564	8-LAZ	2.0
118.523	5-LAZ	1.2	118.565	8-LAZ	2.5
118.524	5-LAZ	1.4			





METAL O-RING

Note

After in-depth testing and analyses, GÜNTHER Hot Runner Technology decided to not install metal O-rings in nozzles, connection pieces, connecting nozzles and hot runner systems. The exception to this is the mechanism of the NEST valve gate single nozzle. A metal O-ring is required here. **No** O-Ring is used between the nozzle and the mechanism.

Damage caused by improperly installed metal O-rings occurs more frequently than over-injection of a hot runner system is prevented by it.

A proper height adjustment made according to our specifications is necessary for a "leak-proof" system.

Please note that a metal O-ring can still be installed in the nozzles, connection pieces, connecting nozzles and hot runner systems if so desired by the customer, but that we make **no guarantees** with regard to proper sealing of the hot runner in such cases.

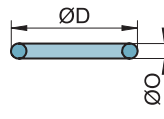

Order designation	Dimension		NEST		
	ØD (mm)	ØO (mm)	8	10	12
810.025	12.70	1.59	•	•	•
810.027	15.59	1.59	•	•	•
810.032	7.70	0.89	•	•	•
810.365	45.82	1.57	•		
810.366	59.82	1.57		•	•



LUBRICATION

Push-type gun for grease

for compressed air; used for maintenance of the needle drive

Order designation	Volume
865.012	653/KM, Contents: 120 cm ³



Lubricant "Barrierta L 55/2"

for the lubrication of sliding mechanism (ANES); long-life high-temperature grease

Order designation	Weight
121.044	800 g



Lubricant "Turmogrease N2"

for the lubrication of single-needle valves (ENV); for long-lasting and continuous lubrication

Order designation	Quantity
121.040	1,000 ml





CLEANING

Cleaning brush for melt channels of type 4–6
for cleaning melt channels with open nozzles

Order designation	Melt channel Ø (mm)
112.231	4
112.232	5
112.233	6



Cleaning brush for melt channels of type 8–12
for cleaning melt channels with open nozzles

Order designation	Melt channel Ø (mm)
112.230	8
112.234	10
112.235	12

